



LSU4 UEGO OPERATORS MANUAL

CONTENTS

<i>Introduction</i>	<i>page 1</i>
<i>Uego Sensor</i>	<i>page3</i>
<i>Installation</i>	<i>page4</i>
<i>Operation</i>	<i>page5</i>
<i>Software</i>	<i>page6</i>
<i>M&W LCD</i>	<i>page9</i>
<i>Kit Components</i>	<i>page10</i>
<i>Graphs</i>	<i>page12</i>
<i>Specifications</i>	<i>page17</i>
<i>Wiring Diagrams</i>	<i>page18</i>

M&W Ignitions

*6 Horning Street
Kurnell 2231
Sydney
Australia*

Ph +61 2 96688348

Fax +61 2 96688209

email: sales@mwignitions.com

Copyright Notice

M&W Ignitions is the owner of Copyright in this publication, including layouts, drawings, text and part numbering systems. This publication must not be reproduced in whole or in part without written authorisation from M&W Ignitions.

Publication Release 1.0

www.mwignitions.com



INTRODUCTION



The M&W Uego system uses a **Universal Exhaust Gas Oxygen** sensor and this works completely differently from a normal oxygen sensor you would find in your car. It allows precise measurement over a wide AFR range.

UEGO sensor systems are used by all original equipment manufacturers for ECU mapping and are also widely used in motorsports including F1.

The microprocessor controlled M&W Uego controller features a fully **linearized real time 0 to 5 volt analog output** giving 10 to 20/1 air fuel ratio.

This simple scaling allows easy input into data acquisition systems and engine management systems. 12V operation with a cigarette lighter plug allows easy fitment for vehicle testing.

The RS232 port allows connection to IBM compatible computers and laptops with DOS, Windows 95/98/NT/2000/XP and PocketPC software available. The controller uses a **true wide range Bosch LSU4** sensor which when used with the tail pipe probe adapter provides a very versatile tuning tool for engine mapping and diagnostic purposes.



INTRODUCTION

Output configurations

0-5V analog output and RS232 provide common interface options.

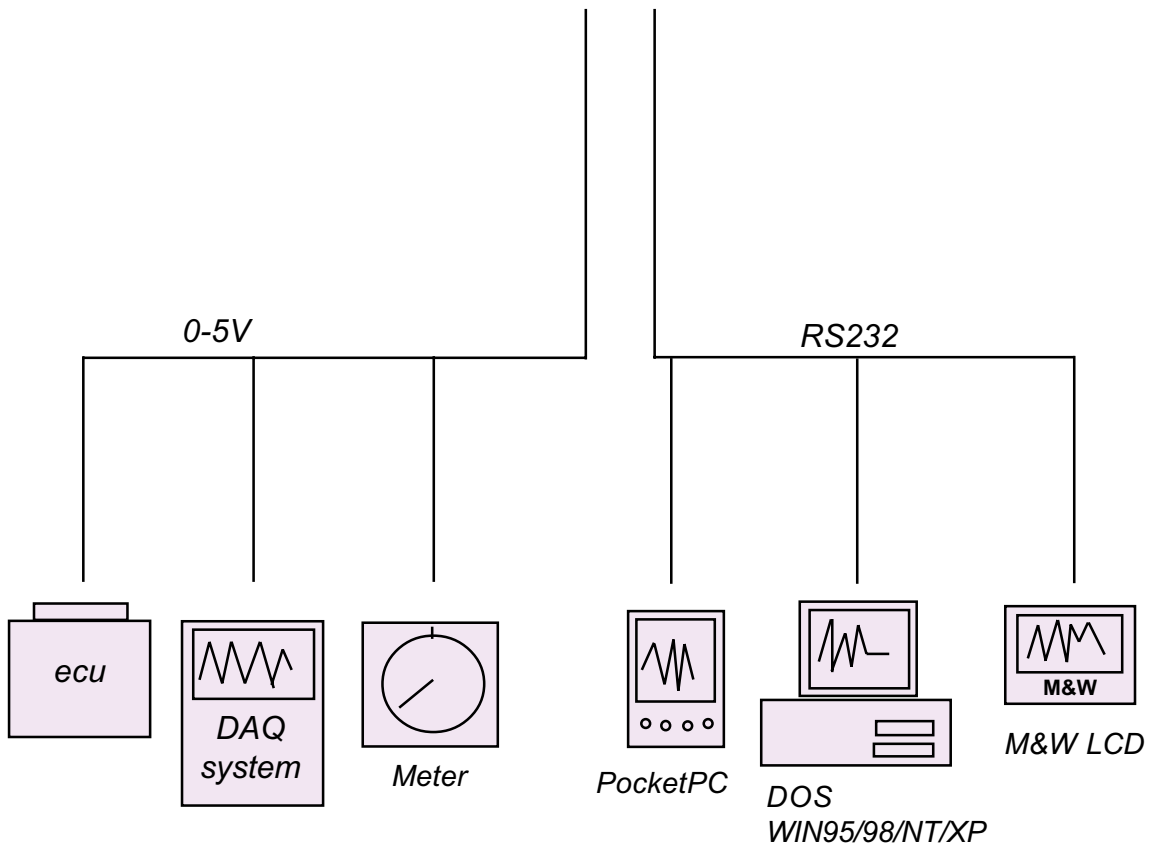

UEGO SENSOR

LSU4 wide range sensor

The sensor uses a special pumping cell which gives a current output depending on the air fuel ratio. This is completely different to a "normal" oxygen sensor. The pumping cell design allows measurement of air fuel ratios over the whole range whereas a "normal" oxygen sensor is only capable of measuring a small range either side of 14.7/1 air fuel ratio. Each wide range sensor is calibrated and supplied with a calibration chip which can be easily changed should a replacement sensor be required.

Note: *the sensor contains a ceramic module and should not be subject to mechanical or thermal shock or it may be damaged.*



Replacement Sensors

Each sensor is individually calibrated and comes with a calibration chip which can be easily changed by removing the controller end plate. The chip should be installed with the correct orientation as shown below.

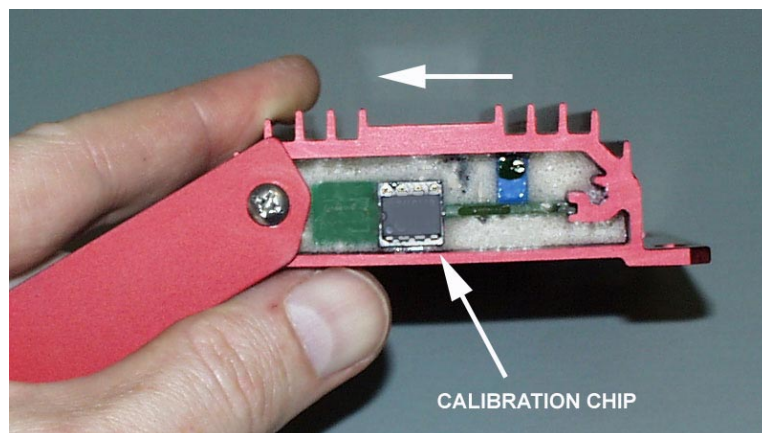

INSTALLATION

Sensor Placement

The sensor may be removed from the tailpipe probe and mounted in the exhaust system. However for general tuning this is not necessary unless you are installing the system in an engine Dyno cell. If the sensor is to be mounted in the exhaust there is no need to place the sensor in the actual exhaust manifold as the sensor heater alone has enough capacity to heat the sensor to operating temperature.

The sensor should NOT be mounted in the exhaust manifold of a turbo charged engine. For turbo charged applications it must be installed after the turbo charger.

Normally the sensor should be mounted at least 1 metre from the cylinder head. Contact us for specific engine dyno installations. For emission's work the sensor may be mounted in the exhaust manifold factory position (normally aspirated only) however the sensor must not exceed 800°C for any length of time.

For installations using the analog 0-5V output to connect to other devices such as DAQ systems, ECU's and other measuring devices the dyno/hardwired wiring harness should be used as this separates the sensor heater ground to eliminate ground loops.

Note: *however if you have a differential input available on your measuring device the lighter socket wiring harness could still be used.*

If used in an engine dyno a suitable regulated +13.8V DC 3A supply must be provided.



Tail pipe probe has a simple clamp mounting. The cable may be installed through the rear hatch or window.

Pre-Post Catalyst Issues

Contrary to popular belief usable results can be obtained post catalyst. For ECU mapping for emissions compliance and for monitoring of perturbation pre-catalyst measurement must be used. A suitable threaded bung must be welded into the exhaust system before the catalytic converter to allow installation of the sensor. However for quick non intrusive general tuning post catalyst with the tailpipe probe works ok. Why is this so? For full load tuning the catalyst is overwhelmed and has minimal effect on the measurement. Note: Actual AFR may be up to 0.3 AFR richer than the tailpipe measurement indicates.

OPERATION

- (1) Insert probe with Uego sensor into exhaust tail pipe.
- (2) Connect controller cable through back windows, hatch or trunk.
- (3) Connect to lighter socket.
- (4) Connect Meter, DAQ system, Laptop/PC, PocketPC or M&W LCD.
- (5) Power may now be applied.
- (6) Warm up cycle will take approx 10-60 seconds. During this time the laptop will display "WARMUP" and if the 0-5V is connected it will be at 2.5V.
- (7) After warmup the current AFR will be displayed and tuning can commence.

NOTE: Do not operate engine without power to controller when sensor is in the exhaust.

Tuning Recommendations

It is outside the scope of this document to describe correct tuning or engine mapping techniques however the following figures are offered as a guide:

Normally asperated engines at full load = 12.5 to 13.0 AFR

Turbo engines at full load = 11.0 to 12.5 AFR.

Cruise mixture both types = 14.0 to 14.7 AFR. (14.7 if closed loop operation)

Much can be learned by checking the manufactures settings as a starting point. The Uego is an ideal tool for such testing.

DO NOT

- (1) Do not operate the sensor with high lead content fuels as this may reduce the sensor life to 50 hours.
- (2) Avoid tuning in the rain with the tailpipe probe as this can cause excessive thermal shock to the sensor which may destroy the ceramic element. Also when tuning boats an influx of water into the exhaust will destroy the sensor if it is immersed.
- (3) Generally do not run the engine with the Uego installed without power applied to the controller.

Tuning Tips

Be aware that on small capacity engines when using the tailpipe probe with big exhausts (eg. turbocharged 4 cyl) it is not uncommon to get erratic measurements at idle. This is due to the small amount of exhaust gas available at idle. Also a strong wind can also affect this. When backing off the throttle while decelerating, erratic readings due to the same problem can be experienced.

SOFTWARE

DOS

System Requirements (Min)

286 20Mhz

VGA

1 X Serial port (Com1 only)

Installation

The EXE file can be run from the floppy or copied to the hard disk. This program is configured for COM1 port only.

Operation

Connect the UEGO serial cable to the COM1 port. Power up the UEGO and run the EXE the message "UEGO ONLINE" should appear in the top right hand corner of the screen. If not then the UEGO system is not powered or the serial cable is not connected to the correct serial port (most PC's have 2 serial ports also most laptops have 1 serial port and this is normally configured as COM1). If online the screen will display "WARMUP" for approximately 10-60 seconds and then the graph trace will begin. Lambda λ or Air Fuel Ratio display may be selected. The supply voltage is displayed if this goes below 12V the heater may not reach the correct temperaure.

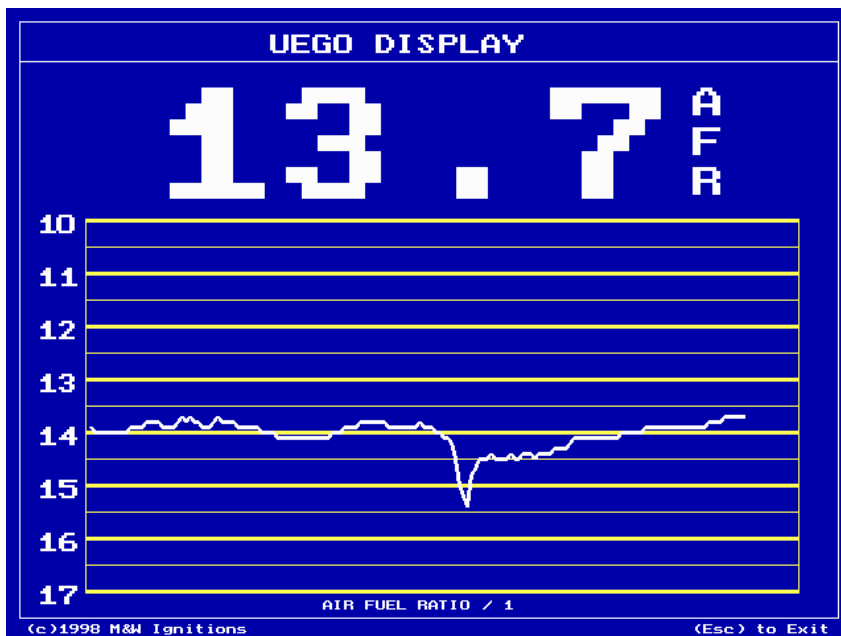

SOFTWARE

Windows 95/98/NT/2000

System Requirements (Min)

486 DX2 50Mhz

VGA

1 X Serial port

Installation

The EXE file can be run from the floppy or copied to the hard disk. There are no DLL's or other files to install.

Operation

Connect the UEGO serial cable to the desired comm port (1 to 8). Power up the UEGO and run the EXE the "UEGO ONLINE" indicator should be green.

(Note: The software defaults to COM1 so if using a different port select it from the "SETUP" pull down menu.) If not then the UEGO system is not powered or the serial cable is not connected to the correct serial port (most PC's have 2 serial ports also most laptops have 1 serial port and this is normally configured as COM1). If online the screen will display "WARMUP" for approximately 10-60 seconds and then the graph trace will begin. Various fuel types and Lambda λ or Air Fuel Ratio display may be selected. The supply voltage is displayed if this goes below 12V the "Low volts" indicator will come on. This is because the heater may not reach the correct temperature at less than 12V.

Version 2.0 and later UegoGraph software allows logging to disk in CSV text format. The text file can then be loaded into a spreadsheet program such as Excel for analysis. The sample rate can be set to Normal (approx. 10 samples per second) or Fast (approx. 15+ samples per second depending on PC speed).

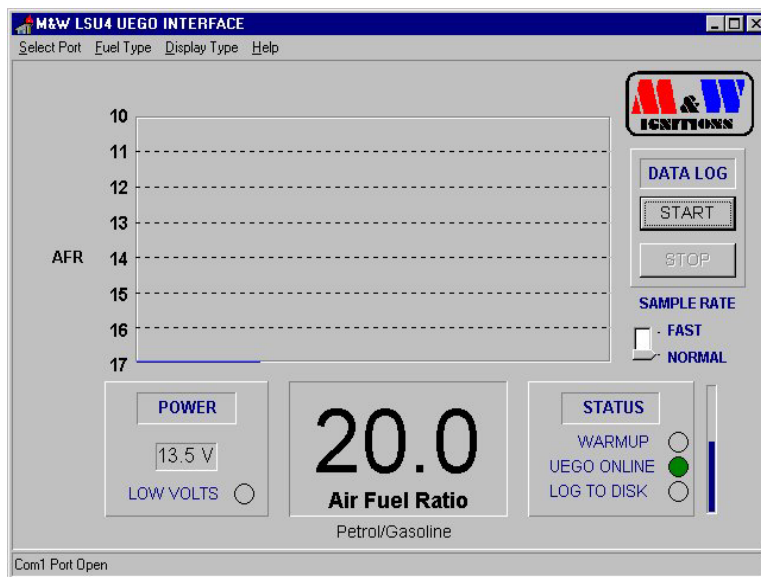

www.mwignitions.com



SOFTWARE

Pocket PC

System Requirements

Pocket PC

WinCE 3.0 or later

1 X Serial port available with 9 pin connector.

Installation

Once the CAB file has been installed the UEGO icon should appear in the Programs Window.

Operation

Connect the UEGO serial cable to the serial port. Power up the UEGO and run UEGO.EXE if online the screen will display "WARMUP" for approximately 10-60 seconds and then the graph trace will begin. If "OFFLINE" is displayed then the UEGO system is not powered or the serial cable is not connected. Lambda λ or Air Fuel Ratio display may be selected. The supply voltage is displayed if this goes below 12V the heater may not reach the correct temperature.



M&W LCD

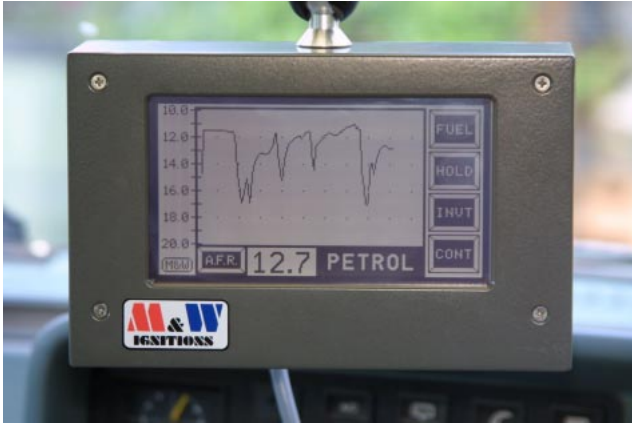

LCD shown supplied with high quality suction cup and swivel mount.

Installation

The four pin connector should be connected to the Uego harness or a 9 pin RS232 cable (on controllers with 9 pin 'D' connector) is used. The LCD is powered by the interface cable so no other connections are necessary.

Operation

Power up the UEGO and if online the screen will display "WARMUP" for approximately 30 seconds and then the graph trace will begin. If "OFFLINE" is displayed then the LCD has power but there is a problem with the cable or Uego controller. The LCD will remember the last settings you used before shutdown.

'CONT' button to adjust the contrast if the display is hard to read.

'FUEL' button selects which of 5 modes the display is using Petrol(Gasoline), Lambda λ , L.P.G. (Liquified Petroleum Gas), Diesel or Alcohol.

'HOLD' button freezes the display for analysis, by pressing the button a second time the display clears and the trace starts over.

'INVT' button reverses the display foreground and background colours for ease of viewing during changing conditions.

The button on the lower left of the screen activates or deactivates the digital display window. With the digital display inactive the sampling rate for the main trace is approximately 21 samples/second and with the digital display active this drops to approximately 15 samples/second.

NOTE

(1) Only use your finger on the touch screen, never use any metal object or sharp implement that may scratch.

(2) Never leave the display hanging from the suction cup unattended as changes in temperature and air pressure may cause it to fall.

STANDARD UEGO KIT COMPONENTS

Standard UEGO Kit contains:

1 X LSU4 UEGO controller.

1 X main wiring harness with lighter plug.

1 X RS232 cable.

1 X tail pipe probe.

1 X operators manual.

1 X LSU4 UEGO sensor.

1 X 3.5" disk with PC software (95/98/NT/XP and DOS) (PocketPC available by request).

MAIN WIRING HARNESS



LSU4 UEGO SENSOR



UEGO CONTROLLER



TAIL PIPE PROBE



PROFESSIONAL UEGO KIT COMPONENTS

UEGO Professional Kit contains:

1 X UEGO controller

1 X main wiring harness with lighter plug.

1 X RS232 cable

1 X stainless steel tail pipe probe

1 X M&W LCD with swivel mount and suction cup

1 X operators manual

1 X LSU4 UEGO sensor

1 X 3.5" disk with PC software (95/98/NT/XP and DOS) (PocketPC available by request).

1 X High quality Pelican carry case



M&W LCD

MAIN WIRING HARNESS



LSU4 UEGO SENSOR



UEGO CONTROLLER



PELICAN CARRY CASE



TAIL PIPE PROBE



Output Scaling

$$AFR = (\text{volts} \times 2) + 10$$

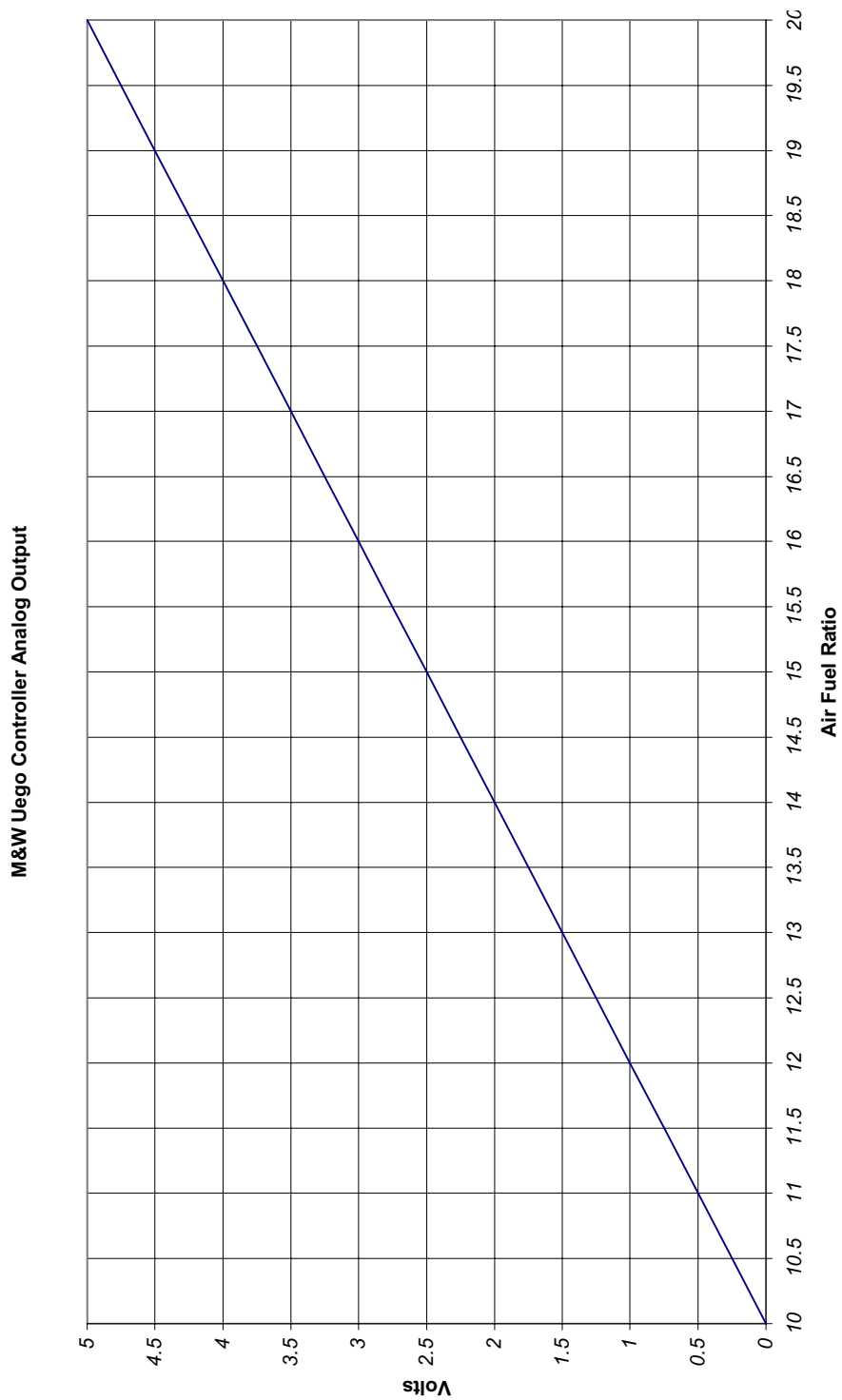

Lambda Chart for Petrol (Gasoline)

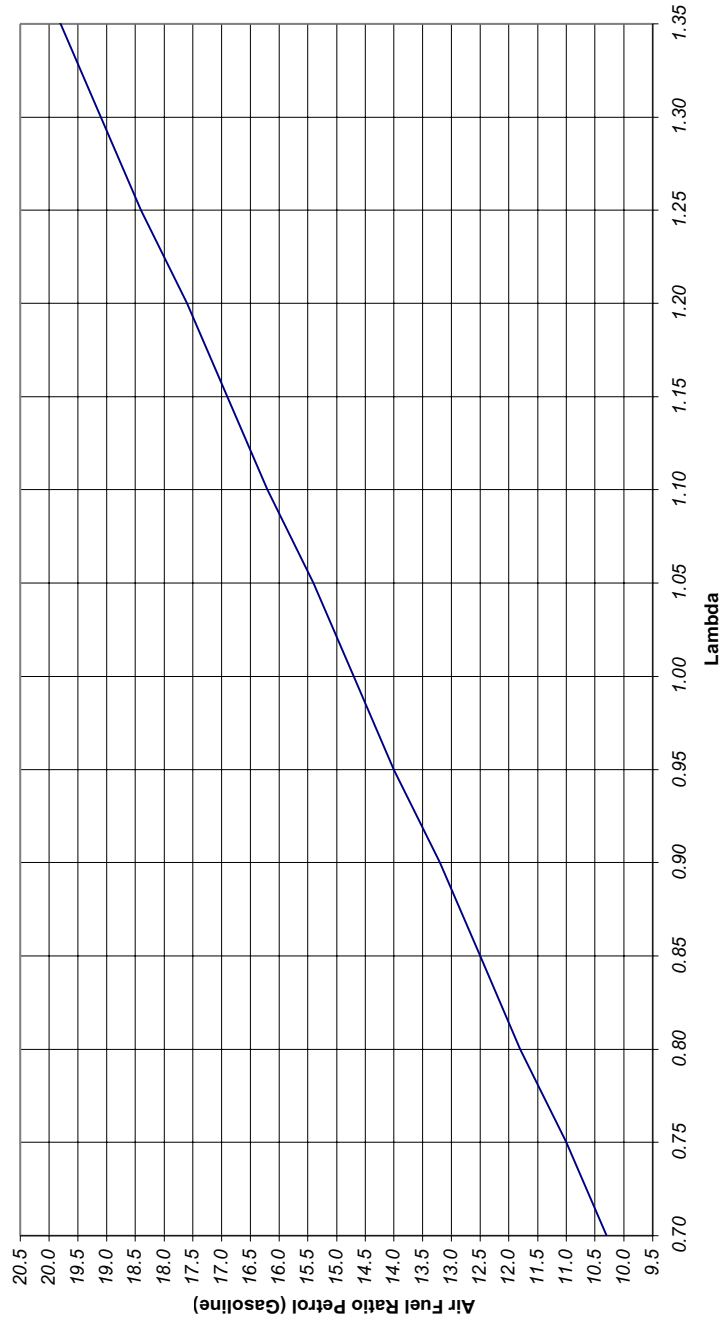

Lambda Chart for Alcohol

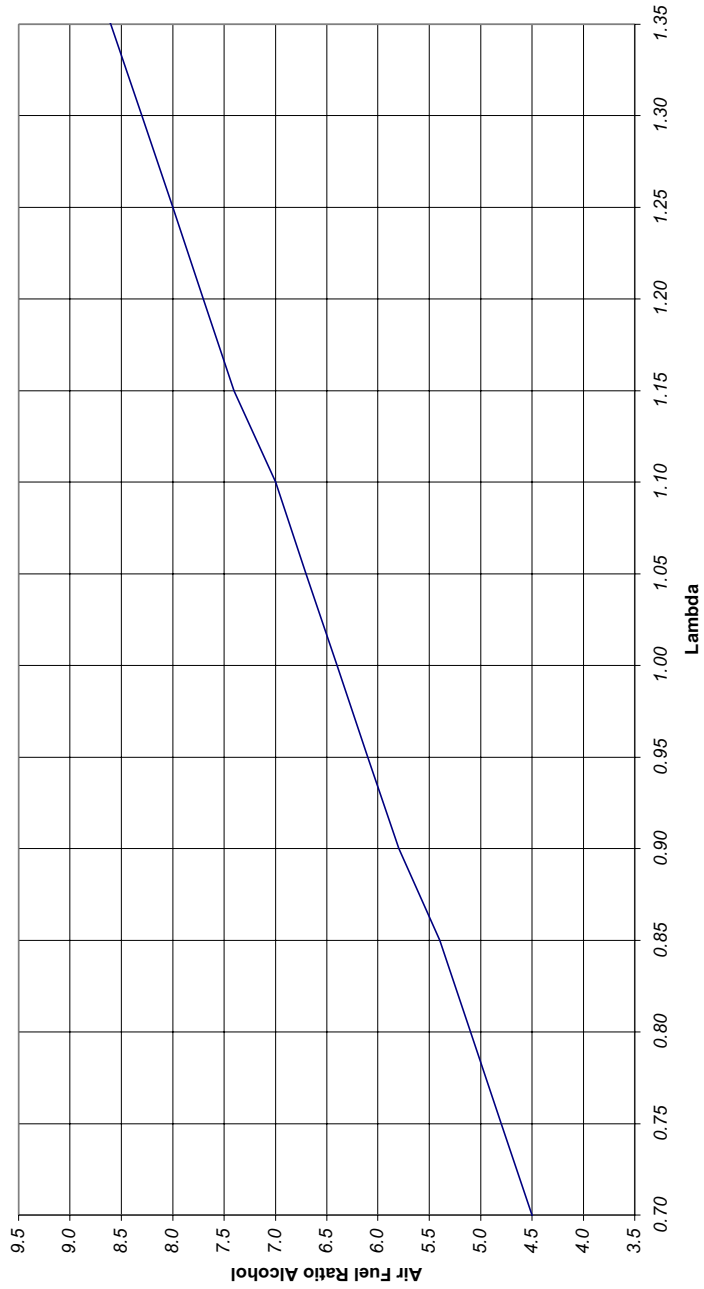

Lambda Chart for LPG (Propane)

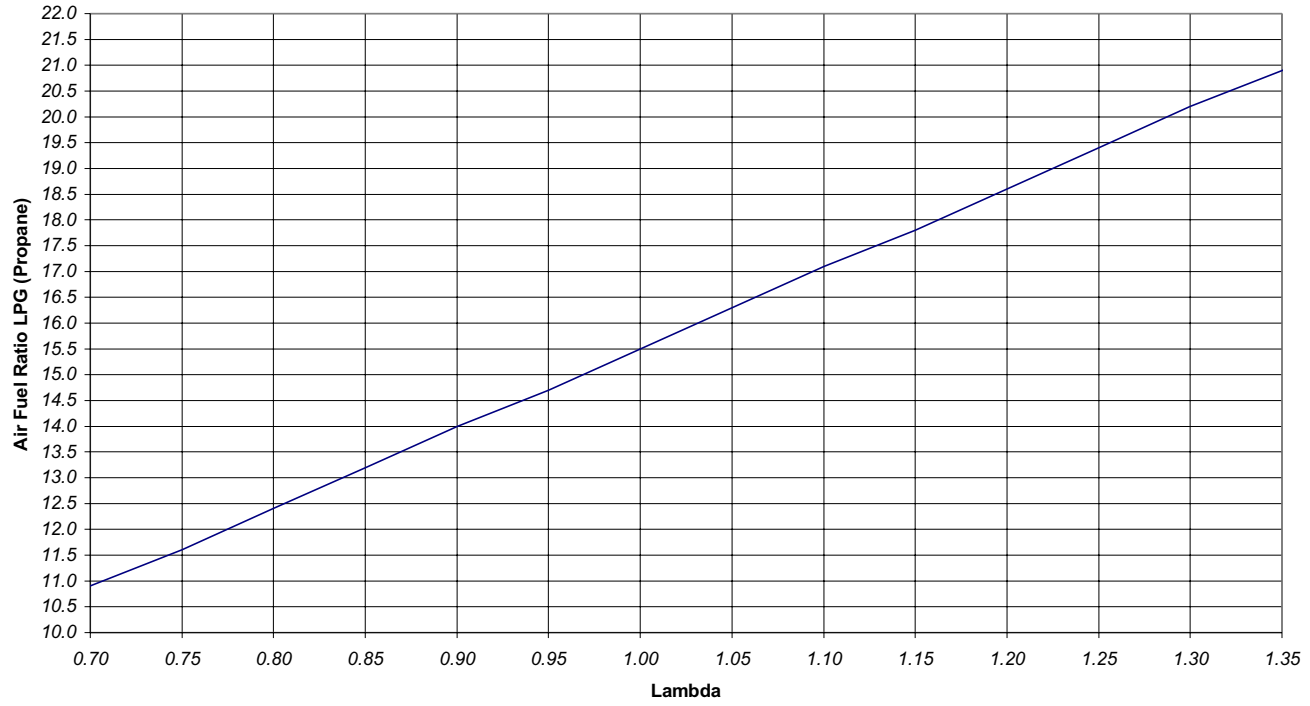

Lambda Chart for Diesel

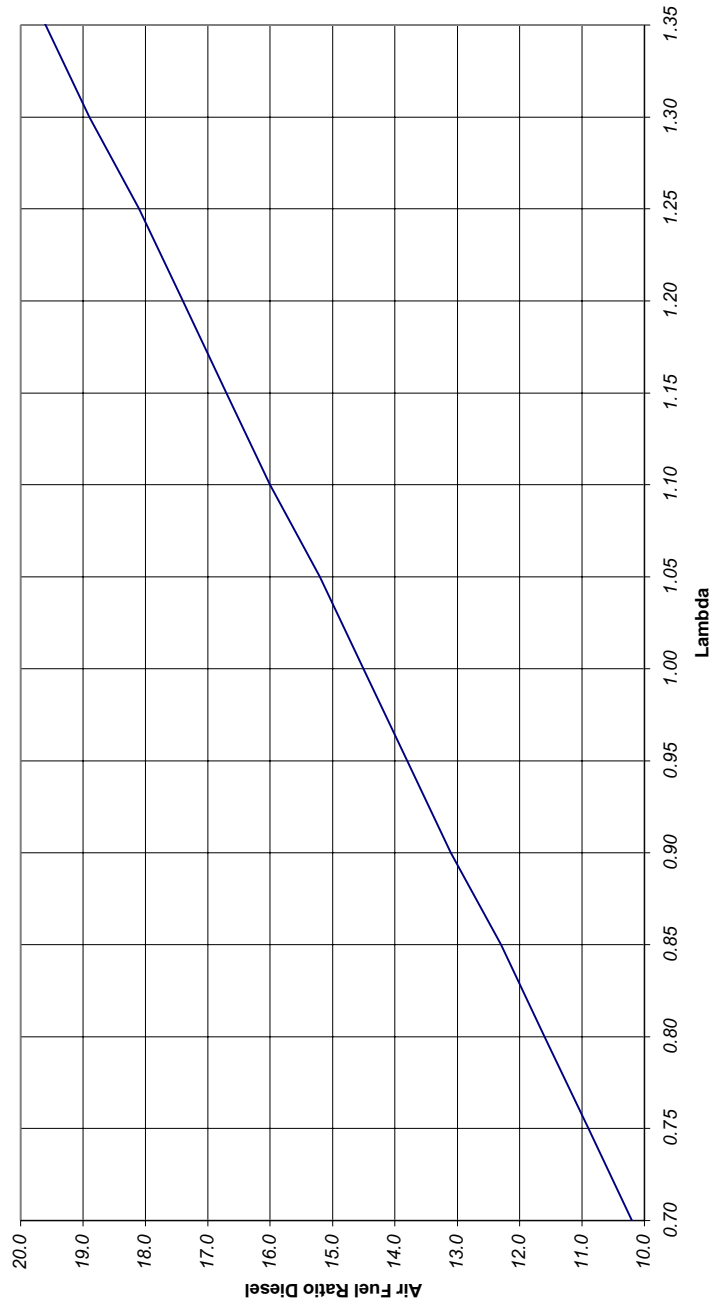

SPECIFICATIONS

LSU4 CONTROLLER

Processor:

8 bit with Eeprom calibration chip

Supply voltage:

12 to 15 volts DC (negative ground only), 200mA (controller only).

Weight:

330 grams

Dimensions:

Width 88mm

Length 105mm

Height 27mm

Inputs:

1 X Uego sensor

1 X supply voltage (internal)

Outputs:

1 X RS232 port

1 X 8 bit DAC 0-5 volt DC analog output

Measuring range:

10 to 20/1 air fuel ratio (petrol/gasoline)



LSU4 SENSOR

Type:

Bosch LSU4 wide range 5 wire sensor. (Exhaust temperature should not exceed 800°C)

Warmup time:

approx 30 seconds @ 25°C ambient

Weight:

85 grams

Heater Current:

1.5A at 12.8V approx. warm

Note: 12V min recommended

Mounting:

M18 X 1.5 thread



NOTE: sensor is not rated for continuous operation on high lead content fuels. Operation in this mode may limit sensor life to approximately 50 hours.

System accuracy:

+/- 0.15 @ 10:1 AFR, +/- 0.025 @ 14.7 AFR, +/- 0.6 @ 20:1 AFR

Controller Repeatability:

+/- 0.01 10-20:1 AFR



Note: 5A fuse in lighter plug

LSU4 UEGO WIRING DIAGRAM

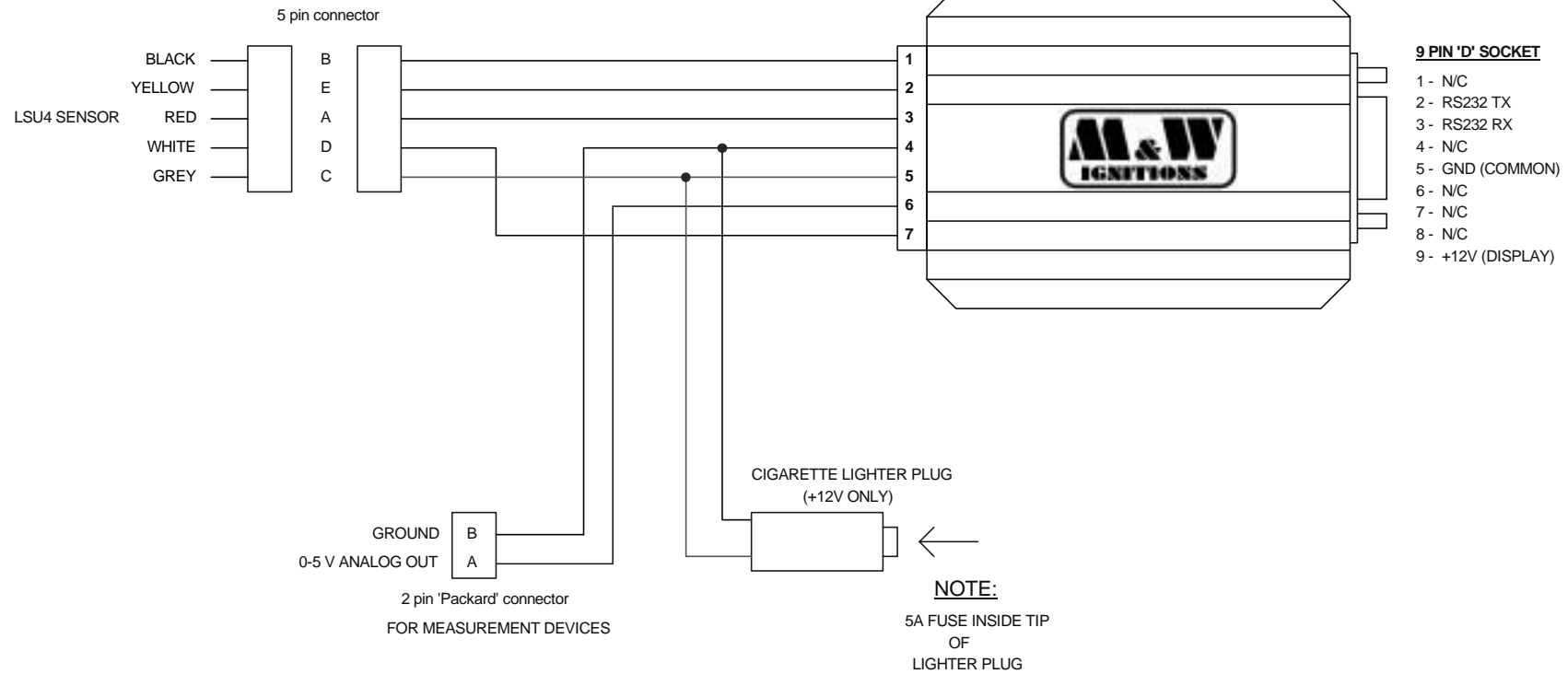

Title			LSU4 UEGO HARNESS		
Size	Number	Revision			
A4	TYPE LSU4	1.1			
Date:	17-Dec-2003	Sheet 1 of	1		
File:	C:\M&W\LSU4 UEGO Harness.sch	Drawn By:	M&W		